



Features

- Low power consumption
- Low voltage drop
- Low temperature coefficient
- High input voltage (up to 24V)
- Output voltage accuracy: tolerance $\pm 3\%$
- TO-92, SOT-89 and SOT-25 package

Applications

- Battery-powered equipment
- Communication equipment
- Audio/Video equipment

General Description

The TX3200_XX series is a set of three-terminal low power high voltage regulators implemented in CMOS technology. They allow input voltages as high as 24V. They are available with several fixed output voltages ranging from 3.0V to 5.0V. CMOS technology ensures low voltage drop and low quiescent current.

Although designed primarily as fixed voltage regulators, these devices can be used with external components to obtain variable voltages and currents.

Selection Table

Part No.	Output Voltage	Tolerance	Package	Marking
TX3200_30	3.0V	$\pm 3\%$	TO-92 SOT-89 SOT-25	
TX3200_33	3.3V	$\pm 3\%$		
TX3200_36	3.6V	$\pm 3\%$		
TX3200_44	4.4V	$\pm 3\%$		
TX3200_50	5.0V	$\pm 3\%$		

Note: "XX" stands for output voltages.

Block Diagram

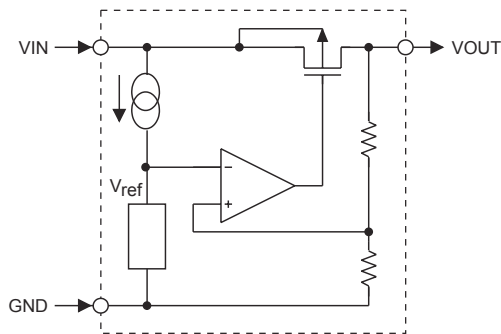



Pin Assignment

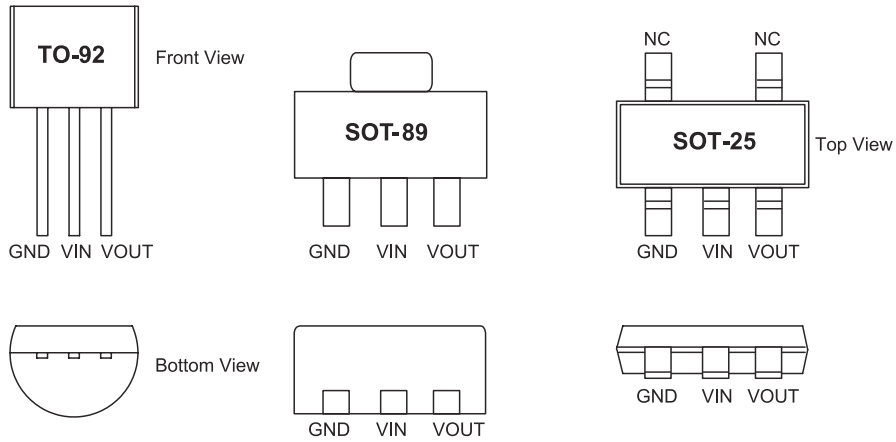

Pad Assignment

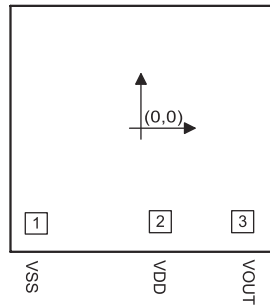

Chip size: 1111×1051 (μm)²

* The IC substrate should be connected to VDD in the PCB layout artwork.

Pad Coordinates

Unit: μm

Pad No.	X	Y
1	-429.00	-401.00
2	123.50	-401.00
3	416.00	-401.00

Absolute Maximum Ratings

Supply Voltage	-0.3V to 26V	Storage Temperature	-50°C to 125°C
Power Consumption (*1)	200mW	Operating Temperature	0°C to 70°C
Power Consumption (*2)	150mW		

Note: These are stress ratings only. Stresses exceeding the range specified under Absolute Maximum Ratings may cause substantial damage to the device. Functional operation of this device at other conditions beyond those listed in the specification is not implied and prolonged exposure to extreme conditions may affect device reliability.

*1: applied to SOT-89 and TO-92

*2: applied to SOT-25



Electrical Characteristics

TX3200_30, +3.0V output type

Ta=25°C

Symbol	Parameter	Test Conditions		Min.	Typ.	Max.	Unit
		V _{IN}	Conditions				
V _{OUT}	Output Voltage	5V	I _{OUT} =10mA	2.91	3.0	3.09	V
I _{OUT}	Output Current	5V	—	20	30	—	mA
ΔV _{OUT}	Load Regulation	5V	1mA≤I _{OUT} ≤20mA	—	60	100	mV
V _{DIF}	Voltage Drop	—	I _{OUT} =1mA	—	100	—	mV
I _{SS}	Current Consumption	5V	No load	—	4	6.0	μA
$\frac{\Delta V_{OUT}}{\Delta V_{IN} \times V_{OUT}}$	Line Regulation	—	4V≤V _{IN} ≤24V I _{OUT} =1mA	—	0.2	—	%/V
V _{IN}	Input Voltage	—	—	—	—	24	V
$\frac{\Delta V_{OUT}}{\Delta T_a}$	Temperature Coefficient	5V	I _{OUT} =10mA 0°C<Ta<70°C	—	±0.45	—	mV/°C

TX3200_33, +3.3V output type

Ta=25°C

Symbol	Parameter	Test Conditions		Min.	Typ.	Max.	Unit
		V _{IN}	Conditions				
V _{OUT}	Output Voltage	5.5V	I _{OUT} =10mA	3.201	3.3	3.399	V
I _{OUT}	Output Current	5.5V	—	20	30	—	mA
ΔV _{OUT}	Load Regulation	5.5V	1mA≤I _{OUT} ≤30mA	—	60	100	mV
V _{DIF}	Voltage Drop	—	I _{OUT} =1mA	—	100	—	mV
I _{SS}	Current Consumption	5.5V	No load	—	4	6	μA
$\frac{\Delta V_{OUT}}{\Delta V_{IN} \times V_{OUT}}$	Line Regulation	—	4.5V≤V _{IN} ≤24V I _{OUT} =1mA	—	0.2	—	%/V
V _{IN}	Input Voltage	—	—	—	—	24	V
$\frac{\Delta V_{OUT}}{\Delta T_a}$	Temperature Coefficient	5.5V	I _{OUT} =10mA 0°C<Ta<70°C	—	±0.5	—	mV/°C

TX3200_36, +3.6V output type

Ta=25°C

Symbol	Parameter	Test Conditions		Min.	Typ.	Max.	Unit
		V _{IN}	Conditions				
V _{OUT}	Output Voltage	5.6V	I _{OUT} =10mA	3.492	3.6	3.708	V
I _{OUT}	Output Current	5.6V	—	20	30	—	mA
ΔV _{OUT}	Load Regulation	5.6V	1mA≤I _{OUT} ≤30mA	—	60	100	mV
V _{DIF}	Voltage Drop	—	I _{OUT} =1mA	—	60	—	mV
I _{SS}	Current Consumption	5.6V	No load	—	3.0	7.0	μA
$\frac{\Delta V_{OUT}}{\Delta V_{IN} \times V_{OUT}}$	Line Regulation	—	4.6V≤V _{IN} ≤24V I _{OUT} =1mA	—	0.2	—	%/V
V _{IN}	Input Voltage	—	—	—	—	24	V
$\frac{\Delta V_{OUT}}{\Delta T_a}$	Temperature Coefficient	5.6V	I _{OUT} =10mA 0°C<Ta<70°C	—	±0.6	—	mV/°C

TX3200_xx



TX3200_44, +4.4V output type

Ta=25°C

Symbol	Parameter	Test Conditions		Min.	Typ.	Max.	Unit
		V _{IN}	Conditions				
V _{OUT}	Output Voltage	6.4V	I _{OUT} =10mA	4.268	4.4	4.532	V
I _{OUT}	Output Current	6.4V	—	20	30	—	mA
ΔV _{OUT}	Load Regulation	6.4V	1mA ≤ I _{OUT} ≤ 30mA	—	60	100	mV
V _{DIF}	Voltage Drop	—	I _{OUT} =1mA	—	100	—	mV
I _{SS}	Current Consumption	6.4V	No load	—	4	7.5	μA
$\frac{\Delta V_{OUT}}{\Delta V_{IN} \times V_{OUT}}$	Line Regulation	—	5.4V ≤ V _{IN} ≤ 24V I _{OUT} =1mA	—	0.2	—	%/V
V _{IN}	Input Voltage	—	—	—	—	24	V
$\frac{\Delta V_{OUT}}{\Delta T_a}$	Temperature Coefficient	6.4V	I _{OUT} =10mA 0°C < Ta < 70°C	—	±0.7	—	mV/°C

TX3200_50, +5.0V output type

Ta=25°C

Symbol	Parameter	Test Conditions		Min.	Typ.	Max.	Unit
		V _{IN}	Conditions				
V _{OUT}	Output Voltage	7V	I _{OUT} =10mA	4.85	5.0	5.15	V
I _{OUT}	Output Current	7V	—	20	30	—	mA
ΔV _{OUT}	Load Regulation	7V	1mA ≤ I _{OUT} ≤ 30mA	—	60	100	mV
V _{DIF}	Voltage Drop	—	I _{OUT} =1mA	—	100	—	mV
I _{SS}	Current Consumption	7V	No load	—	5	9	μA
$\frac{\Delta V_{OUT}}{\Delta V_{IN} \times V_{OUT}}$	Line Regulation	—	6V ≤ V _{IN} ≤ 24V I _{OUT} =1mA	—	0.2	—	%/V
V _{IN}	Input Voltage	—	—	—	—	24	V
$\frac{\Delta V_{OUT}}{\Delta T_a}$	Temperature Coefficient	7V	I _{OUT} =10mA 0°C < Ta < 70°C	—	±0.75	—	mV/°C

Application Circuits

Basic circuits

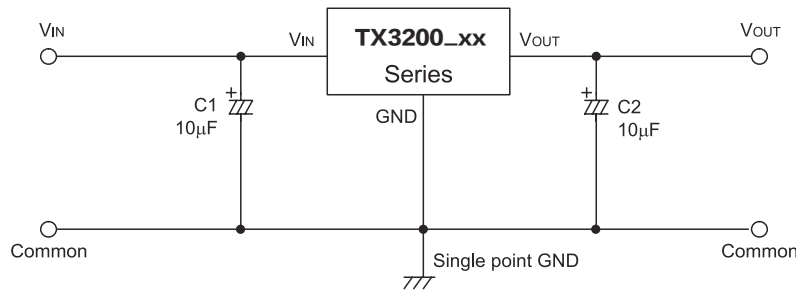

TX3200_xx



High output current positive voltage regulator

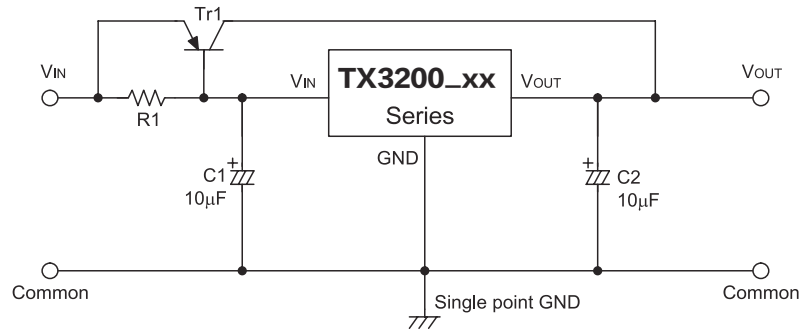

Short-Circuit protection by Tr1

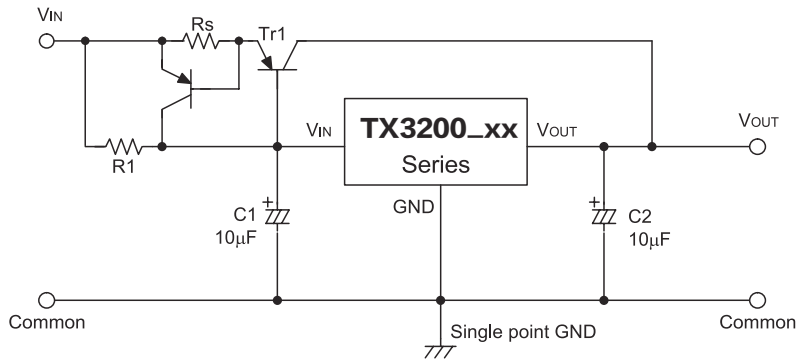

Circuit for increasing output voltage

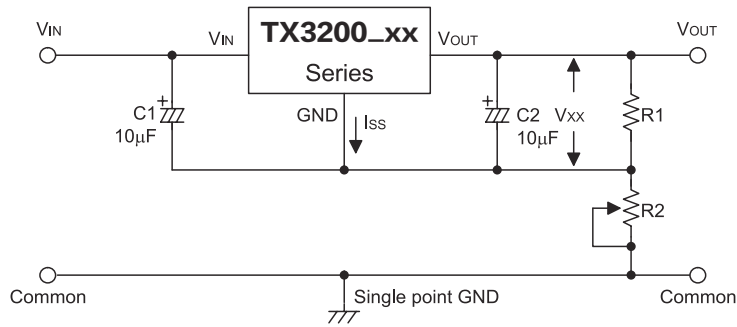

$$V_{OUT} = V_{xx} \left(1 + \frac{R2}{R1}\right) + I_{SS} R2$$



Circuit for increasing output voltage

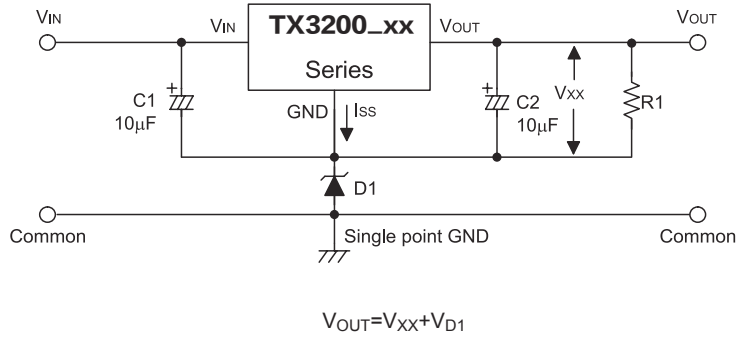

Constant current regulator

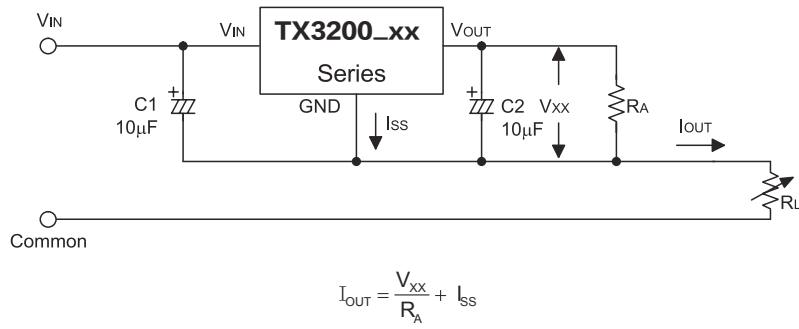

Dual supply

